

Inset LED light Type IL241D ZHR

This very flat inset light was developed for demanding use on apron and taxiways. The requirements according to EASA CS-ADR-DSN Issue 6 (released March 29, 2022) are fulfilled. It is suitable for taxiway systems of categories I to III.

Due to its modular design, the LED unit including power supply unit fits onto existing upper sections and thus enables a resource-saving conversion from IL241 halogen to LED technology.

The IL241D is controlled by constant input voltage with PowerLineControl PLC.

Lights with PLC are controlled and monitored via the lighting bus system BBS. The light intensity is programmed according to the specifications, and operating data from the light is continuously transmitted to the BBS.



Technical data

| | | |
|------------------------|--|--------|
| Casing | Aluminium casting | |
| Protection | IP 68 | |
| Weight | 7.1kg (without shallow base and screws M10x30) | |
| Source of light | LED | |
| Temperature | -25°C to +70°C | |
| Fixation | screwed | |
| Tension | 48V AC max. | |
| Power Pmax. | HPL y/y | 18W |
| | SCL y/y | 22W |
| | TCL b/b | 16W |
| | TCL y/y | 18W |
| | TCL g | 11W |
| | TCL g/g | 20W |
| | TCL o/o | 22W |
| | TSB r | 11W |
| | TSB r/r | 16W |
| Light intensity | HPL y | 320 cd |
| | SCL y | 320 cd |
| | TCL b | 410 cd |
| | TCL y | 635 cd |
| | TCL g | 871 cd |
| | TCL o | 410 cd |
| | TSB r | 760 cd |

Execution and Accessory

| | |
|---------------------|---|
| Drainage | with (HPL, TCL, TSB) without (SCL) |
| Cable length | max. 250 m (for PLC) |
| Accessory | shallow base blind cover screws etc. |

Order Information

| | | |
|---|------------------------------|---------------------|
| Order number | IL241D/v-aaa/ZHR-c1/c2-P-C-o | |
| Version (v) | 1 | unidirectional beam |
| | 2 | bidirectional beam |
| Function (aaa) | HPL | hold position |
| | SCL | stand center line |
| | TCL | taxiway center line |
| | TSB | taxiway stop bar |
| Color code (c1/c2) - (Main beam A/B) | g | green |
| | r | red |
| | y | yellow |
| Option (o) | RF | Retrofit |

Side view

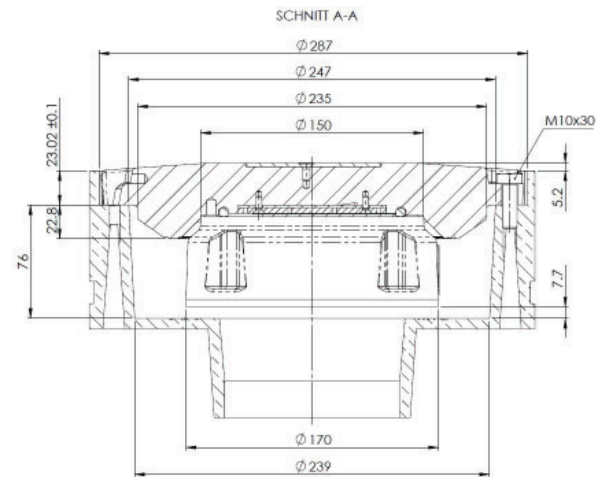
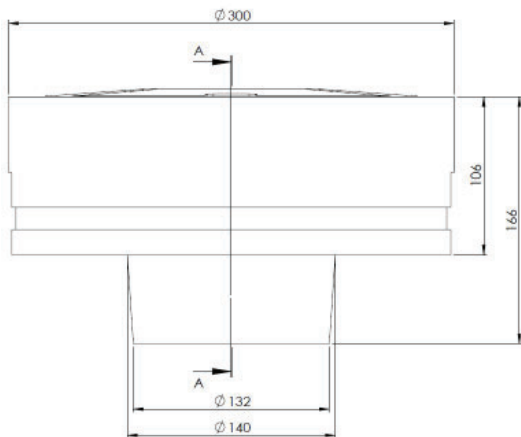

Bottom view

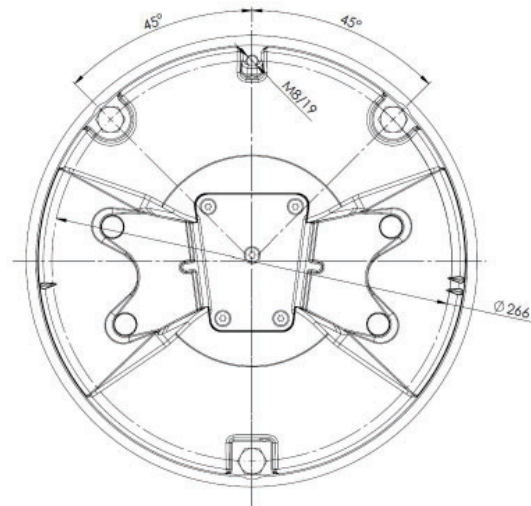

Hugentobler Spezialleuchten AG
 Brunnenwiesenstrasse 14
 CH - 8570 Weinfelden
 Tel. +41 71 626 20 40
 info@spezialleuchten.ch
 www.spezialleuchten.ch



Signalling and alarm lights



Special lights for aviation and navigation



Tunnel safety lights