

LED Storm warning lantern, Type 461

Storm warning and daytime obstruction marker lantern with a light intensity of 140'000 cd (orange) and 200'000 cd (white). Different flashing frequencies can be programmed according to customer requirements. The lantern is available with orange or white LED.

Thanks to modern design, the wind load is kept low. The lantern is robustly built and withstands rough weather conditions.



Technical Data

Casing	anodised Aluminium
Lenses	glass
Weight	35kg
Protection	IP65
Source of light	LED
Light intensity	140'000cd (orange) 200'000cd (white)
Performance @40 Hz	160V A (orange), 312V A (white)
Beam angle	120° (horizontally), 3° (vertically)
Wind load	1000N @ 200km/h
Mounting	by using mounting brackets
Temperature	-55°C to +55°C
Wavelength	584-597nm (orange) 5'700K (white)
Flash duration	250ms

Execution and Accessory

Accessory	Pole and tube adapter according to customers specifications (INOX and hot galvanized) Controls for triggering and monitoring the storm warning light by phone, SMS or radio (digital or analogue)
------------------	--

Order Information

Order number	461-cc-230-ff-bbM-m
LED color (cc)	WH white, OR orange
Voltage	230 230V AC
Flashing frequency (ff)	30 30Hz (obstacles) 40 40/90Hz (storm warning)
Cable length (bbM)	03M 3m cable 12M 12m cable
Mounting (m)	V tube W wall

Overview schematic

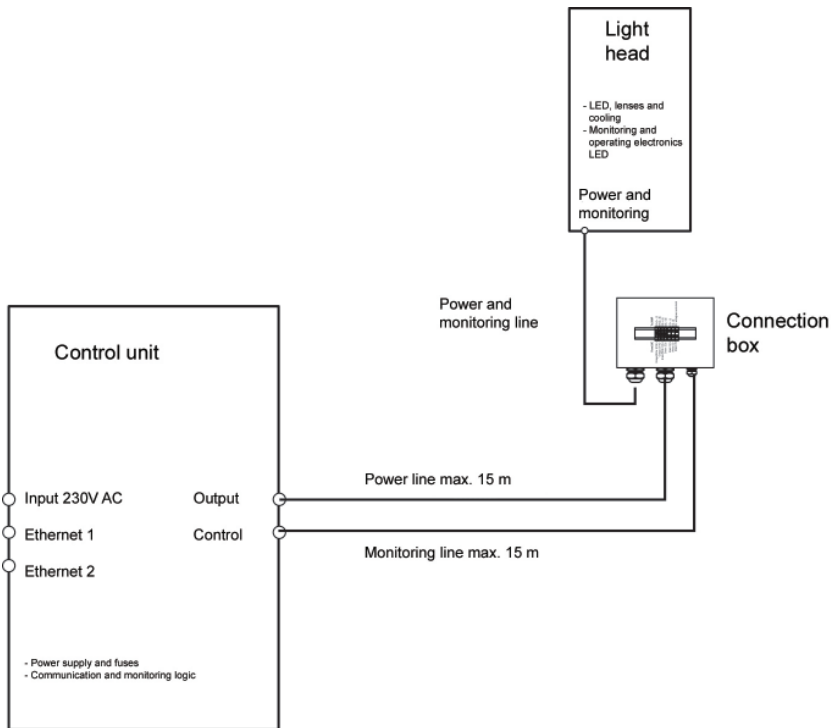

Side view

Front view



Hugentobler Spezialleuchten AG

Brunnenwiesenstrasse 14

CH - 8570 Weinfelden

Tel. +41 71 626 20 40

info@spezialleuchten.ch

www.spezialleuchten.ch



Signalling and alarm lights



Special lights for aviation and navigation



Tunnel safety lights

