

# Solar lantern Type M660

This uncomplicated solar lantern is durable, waterproof, UV-resistant and maintenance-free. The LEDs ensure good visibility.

For temporary marking of port entrances and maritime obstacles.

Various mounting options. Also suitable for mounting on a pole with Ø 70 or Ø 72.

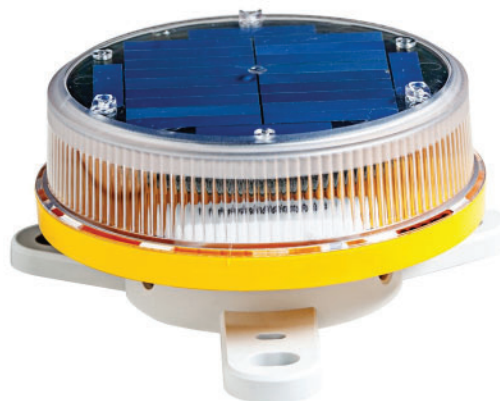

## Technical Data

|                        |   |
|------------------------|---|
| <b>Casing</b>          | Plastic   |
| <b>Protection</b>      | IP 68   |
| <b>Weight</b>          | 0.8kg   |
| <b>Source of light</b> | LED   |
| <b>Temperature</b>     | -40°C to +50°C                                      |
| <b>Mounting</b>        | by using 3 screws                                   |
| <b>Battery</b>         | Li-ions 3.6W / 6 Ah capacity                        |
| <b>Visibility</b>      | 2-3 NM (approx. 5.5 km)                             |
| <b>Beam angle</b>      | 360° (horizontal)<br>> 8° (vertical)                |
| <b>Max. intensity</b>  | WH 71cd<br>RD 40cd<br>GN 42cd<br>YE 52cd<br>BL 18cd |

## Options (not retrofittable)

- ON/OFF wswitch
- Charging socket
- Double battery pack

## Accessory

- Base (incl. screws)
- Programming device / APP
- Battery replacement pack
- Double battery replacement pack
- Battery charger
- Bird deterrent

## Order Information

|                        |  |
|------------------------|--|
| <b>Order number</b>    | M660cc-v   |
| <b>Color code (cc)</b> | WH white      YE yellow<br>RD red        GN green<br>BL blue   |
| <b>Option (v)</b>      | S ON/OFF switch<br>C Charging socket<br>2B Double battery pack |

Side view

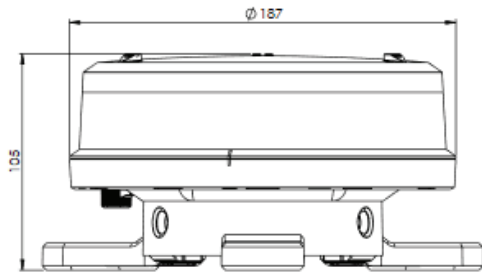

Bottom view

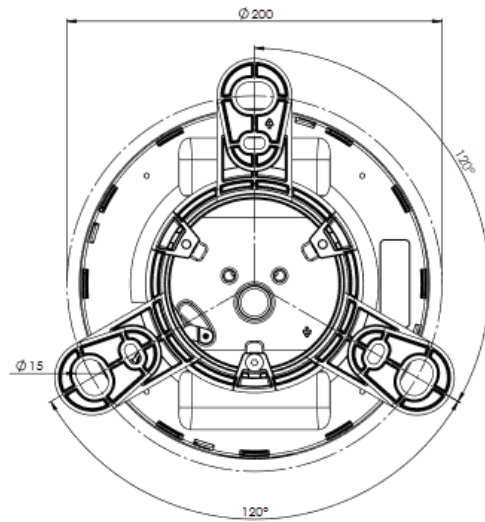

**Hugentobler Spezialleuchten AG**

**Brunnenwiesenstrasse 14**

**CH - 8570 Weinfelden**

**Tel. +41 71 626 20 40**

**info@spezialleuchten.ch**

**www.spezialleuchten.ch**



**Signalling and alarm lights**



**Special lights for aviation and navigation**



**Tunnel safety lights**